

OPTICAL NETWORK FOR HOME AND OFFICE
PRODUCTS AND SYSTEMS 

homeibre

THE NETWORK IS THE KEY TO THE DIGITAL FUTURE HOME

CONNECTIVITY REDEFINED

New digital services such as IP-TV, HD & UHD TV, online games, HD video telephony or 3D TV and Augmented Reality are forcing their way into the market. As a result of the massive expansion of the access networks with high bandwidths (FTTH, VDSL, etc.), system providers are increasingly offering higher quality services. In addition, personal digital content such as videos, photos, music and data are being stored at home and transmitted to several appliances. In the field of home automation, energy management and safety, systems and applications are more and more networked with PC, smart phones, tablets, voice-controlled intelligent personal assistant services and touch screens.

In the ideal network fix wired applications and mobile devices are used in an optimized way. Free frequencies are a limited resource and should only be occupied with mobile applications. Services with high bandwidth demand work best when linked to a wired network.

In order to ensure a long-term, consistent and issue free functionality of an integrated network, a stable and reliable infrastructure and transmission technology is required in the home. It should be widely available and offer the highest possible number of connection possibilities. For us at Homefibre, the ideal solution is an optical data backbone.

Together with its cooperation partners, Homefibre has set itself the goal of offering innovative products and system solutions, as well as technical support for the planning and installation, that deliver environmentally safe and reliable digital home networking.

With the Polymer Optical Fibre (POF) we use a proven technology that is ideally suited to a new and innovative infrastructure which satisfies these demands.



Josef Faller
Managing Director



ALL-IP APPLICATIONS AND SERVICES

Digital applications and services will be networked and connected more and more. Today IP-based Internet services are combined with an increasing number also from home internal sources (NAS).



ISP
IP-TV

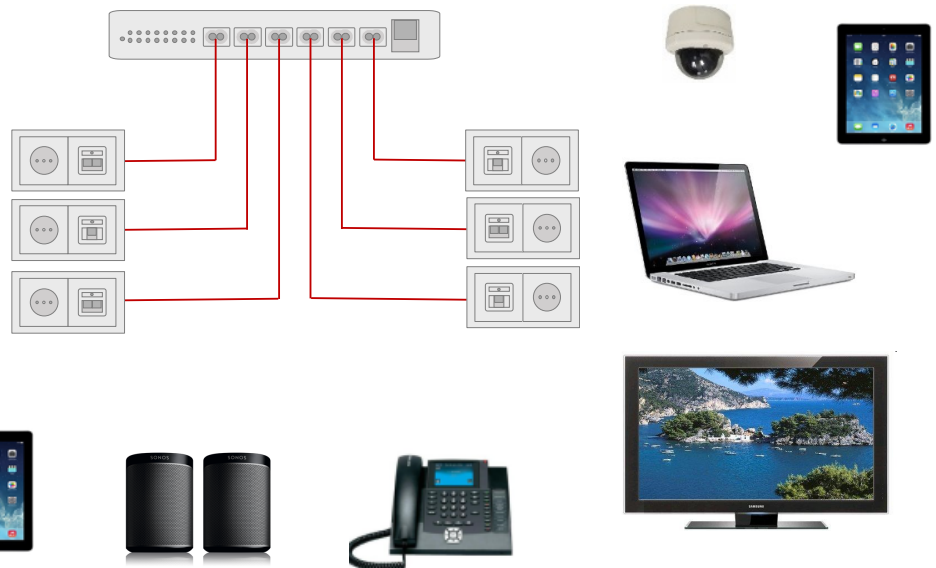

Smart Home - App Control
(heating, climatisation, energy, shutter, light etc...)
AAL
(Ambient Assisted Living)
Safety & Security

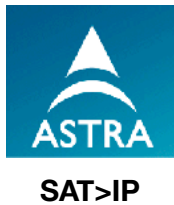

VIDEO & AUDIO	GAMING & TELEPHONY	SMART HOME & SECURITY
<p>BANDWIDTH</p> <p>High Definition Video Streaming and other video services e.g. HDMI over IP need a high and reliable bandwidth. Music and radio can also be streamed via the internet and/or from an internal home audio server. Loudspeakers and other audio clients today are a capable of the IP technology as well and need to be connected to the home network.</p>	<p>RELIABILITY</p> <p>For gaming and telephony the latency has to be constant and as small as possible. There is nothing worse than not being able to respond to the other person on the call or to react to the moves of the other players in an online game.</p>	<p>SECURITY</p> <p>Due to security reasons devices like security cameras or door bells should be connected to a wired network. Smart home devices are more and more connected over wireless technologies. Also, it's common to use mobile devices for the controlling of smart home applications. These devices need an optimized WiFi coverage and fix installed devices e.g. touch panels should be hooked to a wired network.</p>

THE OPTICAL IN-HOUSE BROADBAND NETWORK

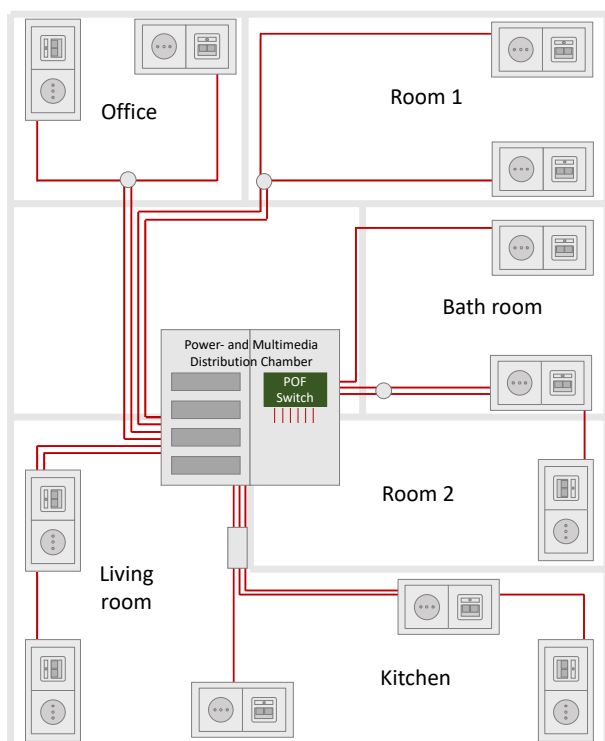

With the concept of optical in-house broadband cabling, Homefibre offers a future-proof and easy installation infrastructure solution which enables the integration of computer, multimedia and home automation systems in an ideal way via Ethernet and IP (Internet protocol).

The optical cable which is made of Polymer Optical Fibre (POF) has been successfully used in the automotive sector and in the industry for many years. The POF cable is robust and can be easily installed and connected. It can be installed separately or drawn into a conduit together with the electrical installation. Every plug socket in the house can thus be inexpensively equipped with a data interface. It is also available for a data connection in all splitter boxes.

All IP-based automation systems in the house can be linked via the optical cable and integrated into one system with computers and multimedia devices.

The benefits of the Homefibre system are:

- * **reliable** and **stable** data transmission
- * **unaffected** by electromagnetic interference
- * **radiation-free**: no electromagnetic smog via the leads
- * **simple** and **variable** installation
- * **low power** consumption of the components
- * **lightning protected data link** due to galvanic isolated POF cable



USER INSTALLATION

EASY

Thanks to its simple handling the POF cable can even be installed by non-experts.

The small cable diameter allows the cable to be placed and concealed behind the skirting board or under the carpet.

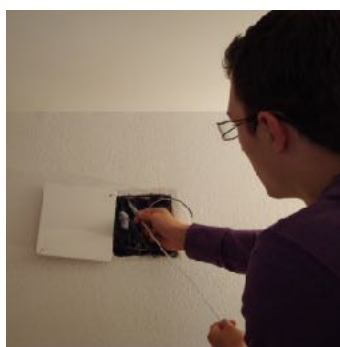

FOR RETROFITTING

FLEXIBLE

The POF cable can be easily integrated into the existing electrical installation without cutting channels or drilling.

Flush-mounting plug sockets, flush-mounting switches or plug socket adapters serve as interfaces between your device and the network and can be installed as standard in your home.

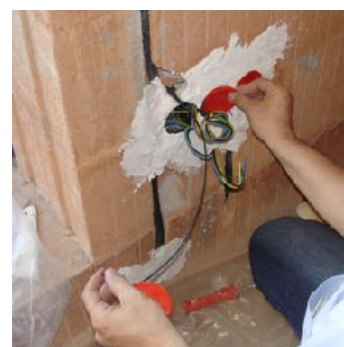

FOR NEW BUILDINGS

FUTURE-PROOF

In order to minimize the installation costs of a full-size home network, it is sufficient to lay an inexpensive POF cable together with the electrical cables during the initial installation. A safe optical data port can thus be prepared at each main plug socket.

With the flush-mounted optical media switches from Homefibre, the connection is converted into a standard Ethernet port with two RJ45 interfaces or a one RJ45 interface and WiFi access.

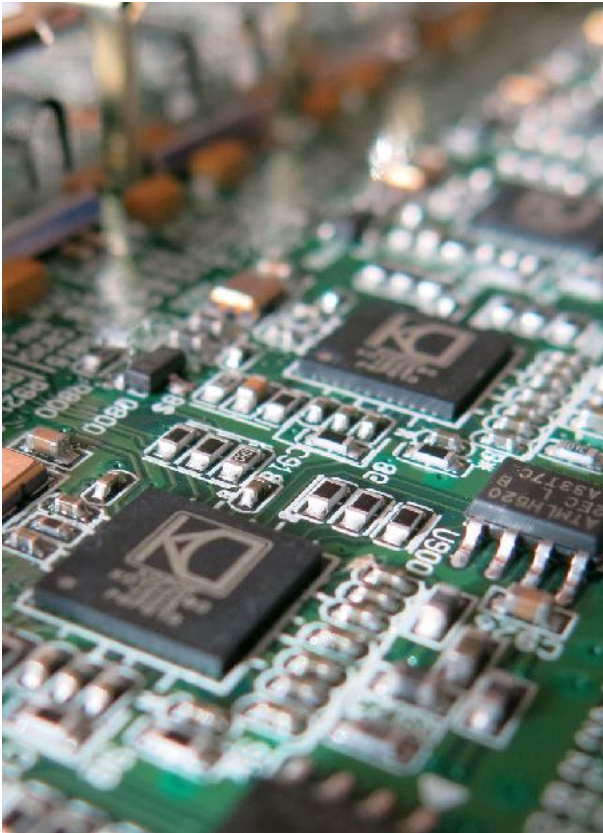

THE TECHNOLOGY

For the optical transmission, electric signals are converted into optical signals, transmitted by light and then converted back into an electric signal by a media converter. Nowadays, red light with a wavelength of 650 nm is used for the transmission.

With the availability of Gigabit transmission over Polymer Optical Fibre (POF) the installation of powerful networks becomes much easier.

The Gigabit system components are compatible with all common devices using the international standard IEEE 802.3ab. The Gigabit technology by KDPOF makes it possible, to transmit data with 1 Gbps over 50 m POF cable. An adaptive smaller bit rate is used for the transmission up to 80 m.

The Gigabit system components are backwards compatible to 100 Mbps components so that both device generations can be mixed in a system. In this case a transmission rate of 100 Mbps will be used by the Gigabit devices for these transmission paths.

Homefibre offers a wide range of optical media converters and optical POF switches for the installation of a network. The integration of WiFi is also possible with our innovative products.

THE OPTICAL TRANSMISSION	TRANSMITTER AND RECEIVER	CABLE AND COMPONENTS
<p style="text-align: center;">RADIATION-FREE</p> <p>The optical transmission is unaffected by electromagnetic interference and does not conduct electricity. As a result the cable can be installed together with the electrical installation, which significantly reduces two important factors: cost and time.</p> <p>The optical transmission can be tested by measuring the light intensity in dBm at both ends of the optical cable.</p>	<p style="text-align: center;">RELIABLE AND STABLE</p> <p>The optical interfaces consist of transmitters and receivers. With the POF cable a reliable and stable connection for both transmission directions is established.</p> <p>The optical transmission uses visible- and for human eyes safe- red light with RC-LED (Resonant Cavity Light-Emitting Diode) offering easy checking for the functionality of the connections.</p>	<p style="text-align: center;">LOW POWER CONSUMPTION</p> <p>The POF cable is sturdy, has a small diameter and is very low in weight. The typical cable rating is approx. 15 dBm to 18 dBm per km. Approx. -7 dBm are measured directly at the connection.</p> <p>The optical cable can be connected to the optical interfaces of the system components without plugs (e.g. Optolock) or with an easily fitted plug (e.g. SMI connectors)</p> <p>The receivers can process a signal down to -24 dBm.</p>

QUALITY AND COMPATIBILITY

30 / 50 / 70 / 80 / 90 m POF cable
RHEE 4002 (Class A4a.2)

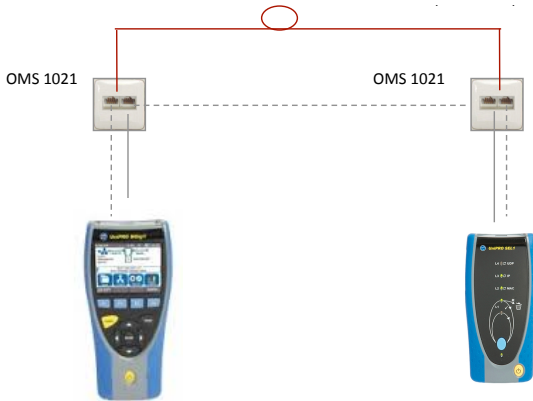

Test setup RFC2544 and SLA-tick test

At homefibre digital networks, products and applications are tested comprehensively in different scenarios. These tests follow international standards and procedures (e.g. RFC2544).

In these tests we verify the maximum transmission rates based on different packet sizes in data transmission.

Beside standardized test procedures we also implement the comparison of other network solutions and testing in different network scenarios and with different applications to ensure quality and compatibility.

We know that in the end only the real quality of the data and transmission connection is what counts.

50 METER

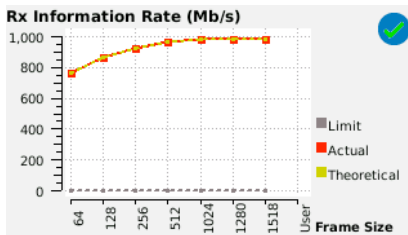

Test Nr: OMS1021_DV_TEST 001
Optical power: approx. -12.6 dBm

60 METER

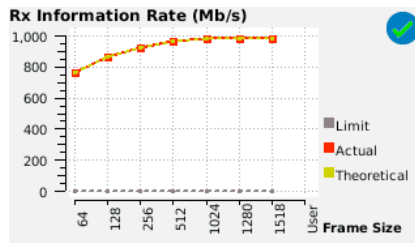

Test Nr: OMS1021_DV_TEST 008
Optical power: approx. -14.9 dBm

80 METER

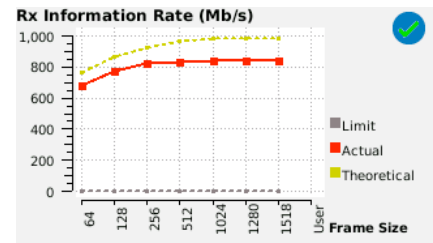

Test Nr: OMS1021_DV_TEST 014
Optical power: approx. -17.9 dBm

NOTE: The performance with Adaptive Bit Rate (ABR) depends on several parameters (e.g. cable attenuation, LED source power, LED receiver sensitivity, operating temperature).



STANDARDIZING

The POF home network is based on international standards and specifications.
IEC 60793-2-40:
 Optical fibres -Part 2-40
ETSI TS 105 175-1 V2.0.0 (2011-10):
 Access, Terminals, Transmission and Multiplexing (ATM); Plastic Optical Fibre Syst. Spec. for 100 Mbps and 1 Gbps
ISO 11801:
 Information Technology - Generic Cabling for Customers Premises
IEC 60825 series:
 Safety of laser products
DIN EN 50173:
 Dimensions and broadcasting requirements
IEEE 1000Base-RHx (working group)

INTEGRATED NETWORK

The optical network components are integrated in the electrical installation. Wall outlets and network access points are available everywhere in the home. Devices can be linked to the network at several points as required in each room.

 This results in reliability because the risk of damage of scattered devices, cables or connections is reduced immensely.

ONE NETWORK FOR ALL

The POF cable is available everywhere in the electrical installation.
 This allows to link new IP applications easily, fast and safely to the network.

 For example an in-wall distribution box enables to integrate a switch with sensor interfaces or security cameras to the network at any time.

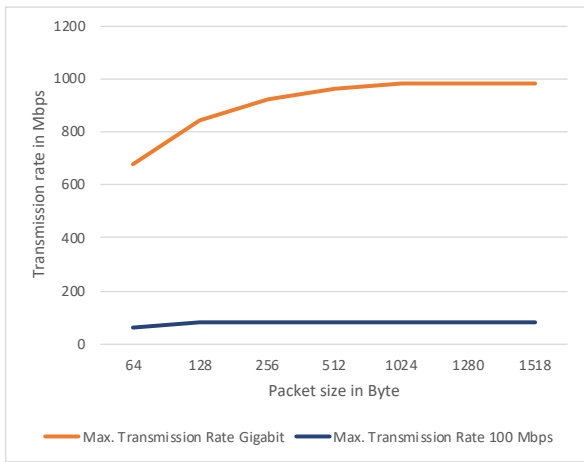

COMPATIBILITY

Although many end devices in the consumer sector are still equipped with 100 Mbps interfaces, Gigabit Ethernet transmission is also largely standard in the home network.

Many Homefibre network components are therefore available in a 100 Mbps and Gigabit version, with focus on full compatibility of the components in the overall system.

For both technologies the same POF fibre is used.

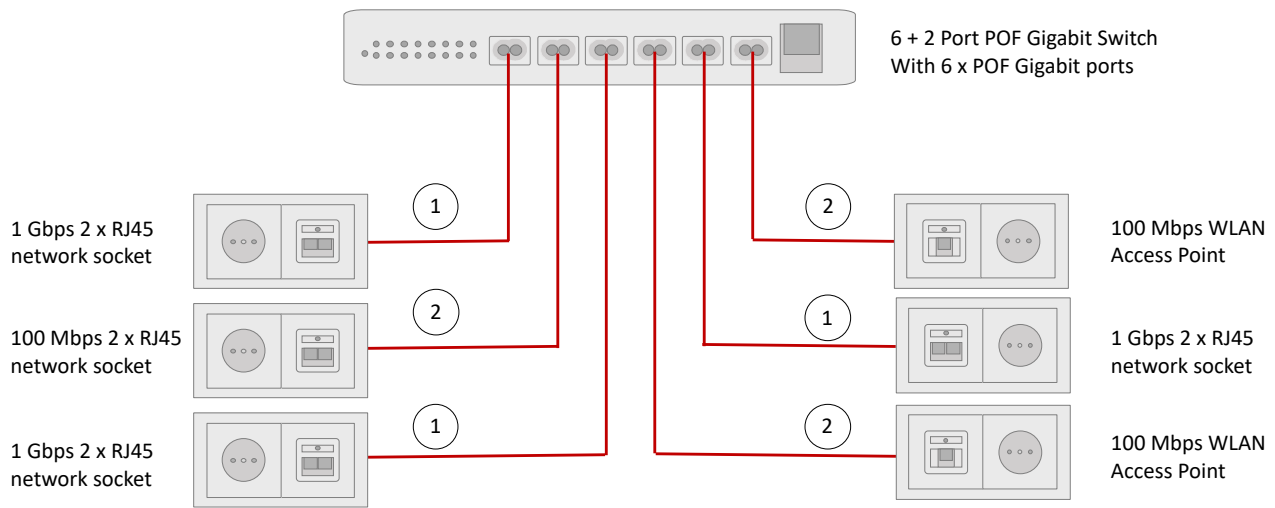

Gigabit Ethernet

1

1 Gbps Ethernet transmission

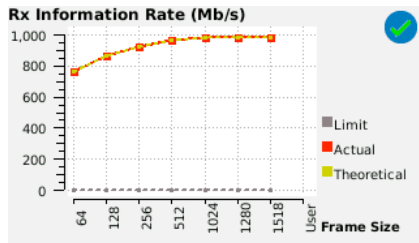

Fast Ethernet

2

100 Mbps Ethernet transmission

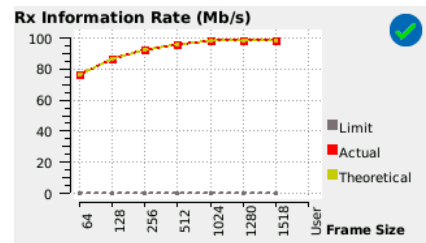

COST- AND DEMAND ORIENTED

If only certain Gigabit routes are required in a system installation, you can run some routes with 100 Mbps components and only where required with 1 Gbps components. The central Gigabit switch is fully backward compatible to all 100 Mbps devices.

SYSTEM UPGRADE

If upgrades are required for an existing 100 Mbps system, these can also be done without great effort. Only the respective network components need to be replaced. The cable is used as usual. A full Gigabit transmission rate is possible up to 50 m cable distance. For longer cables, ABR technology (Automatic Bitrate Reduction) enables transmission at a reduced information rate (e.g. approx. 700 Mbps over 70 m).

MIXED SYSTEM

Please note that you need a Gigabit network component at both ends of the transmission path for Gigabit transmission. If a Fast Ethernet (100 Mbps) and a Gigabit component are used together, the two network components agree on the transmission with 100 Mbps. Usually, the central switch is a Gigabit switch.

THE SYSTEM

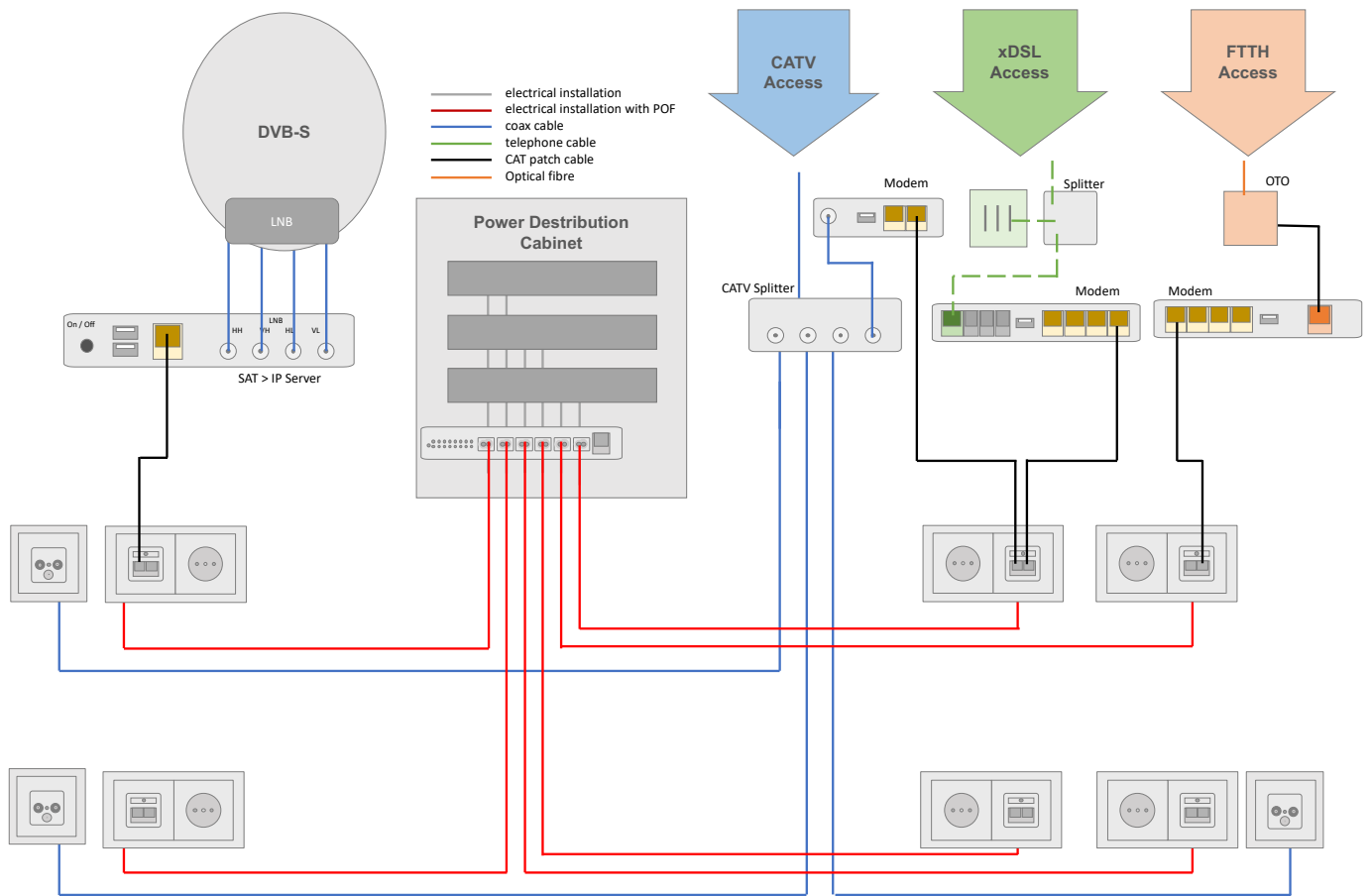

A POF network is installed as a structured cable installation. The optical core network provides higher availability and flexibility in realizing an innovative network infrastructure. In combination with the electrical installation it is a data backbone for all IP applications. It results in a star-tree structure, in which - based on your demand - different network applications and services can be integrated in every part of your home.

The central switch is either placed close to the power distribution cabinet or inside the electrical distribution cabinet. The access (e.g. Modem, Router, SAT>IP Server, etc...)

can be connected to the network everywhere in the house.

The thin POF cable (2.2 / 4.4) mm can be used for retrofit with little space and the network components can be placed in a distribution cabinet.

The interfaces for the network devices are common RJ45 ports or WiFi access points.

Through the star structure the connection to the internet can be established with every access point in the house. The wired network offers the highest possible

bandwidth for each data port independent of the direct distance to the router.

The network can be established as a Fast Ethernet network, a Gigabit Ethernet network, or as a combination of both options depending on the demand.

*IP = Internet Protocol over Ethernet

APPLICATION: INTEGRATED IP NETWORK

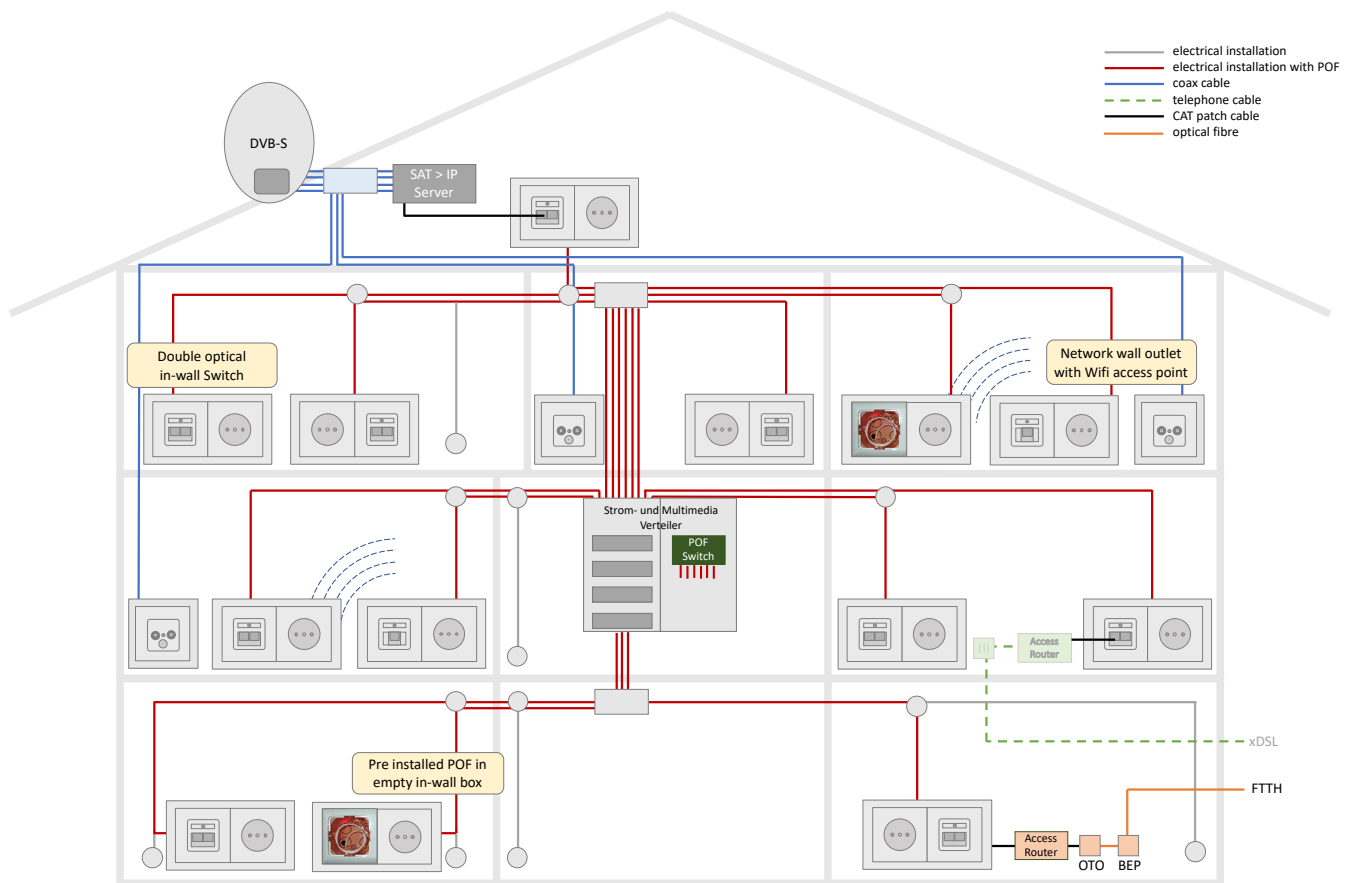

The draft above shows a house with combined POF and electrical installation. The main parts of the power sockets are wired with a POF cable. In this way multiple network interfaces can be prepared for further use. This is one of the big advantages of a Homefibre system.

A data socket or a WiFi access point is installed where it is needed. In other power sockets the wire will be “parked” invisibly behind a power socket or visibly with a low-cost optical network multimedia interface (SMI-Interface).

Additional POF cable can also be placed at the junction boxes. This gives the possibility to add additional devices e.g. switches, sensors, cameras, components for smart homes, etc. at any given time and without any extra effort.

IP-TV, Internet television or internet streaming services are received via the access router (modem).

Also satellite TV can be transmitted over the POF network and the WiFi access points via SAT>IP in the whole house.

The combination of optical wired backbone and WiFi grants an optimized network coverage in the whole house. Smaller WiFi clusters help to reduce the intensity of electromagnetic fields and improve the performance for WiFi access. Smaller WiFi clusters can also be switched on or off depending on personal preferences of the user.

APPLICATION SCENARIOS / EXAMPLES

Simple point to point solution

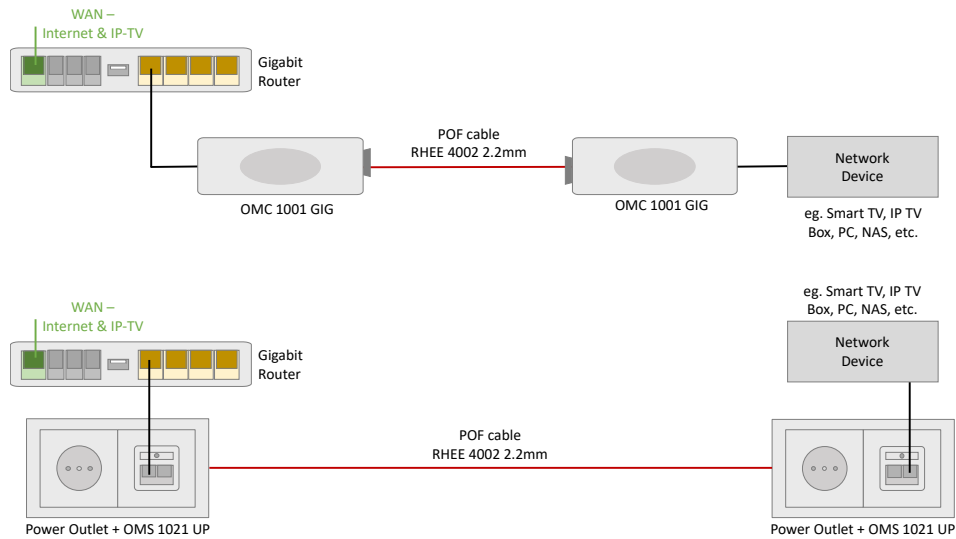

In the first example a simple point to point connection with an OMC 1001 GIG media converter set is used to connect the computer with the router of the internet service provider so that the internet services can be used.

As you can see in the second example it is also possible to install a point to point link with two wall outlet switches OMS 1021 UP-GIG or OMS 121 UP.

Easy home network solution

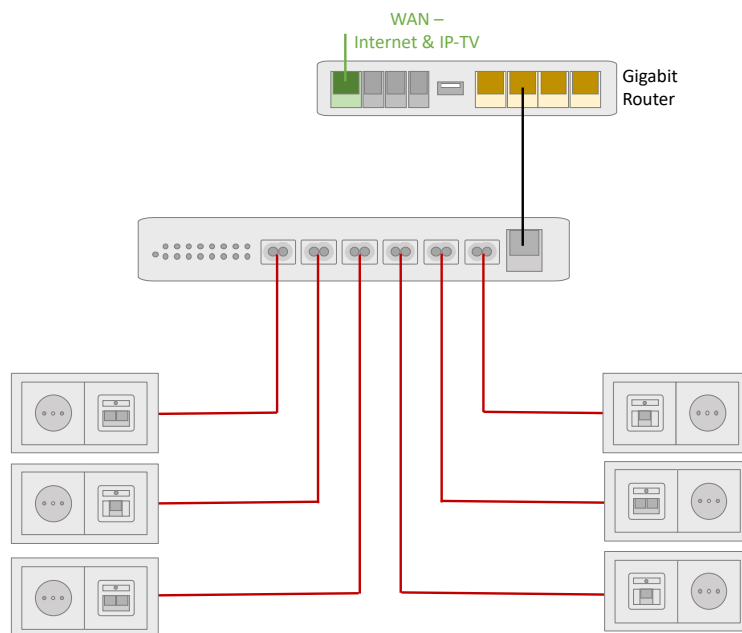

This example shows a typical solution for a POF home network with six connections. Gigabit data outlets (OMS 1021 UP-GIG) and 100 Mbps data outlets (OMS 121 UP) and WiFi access points (OMA 111 A2 WLAN) can be used in any combination. All components are compatible with each other.

APPLICATION SCENARIOS / EXAMPLES

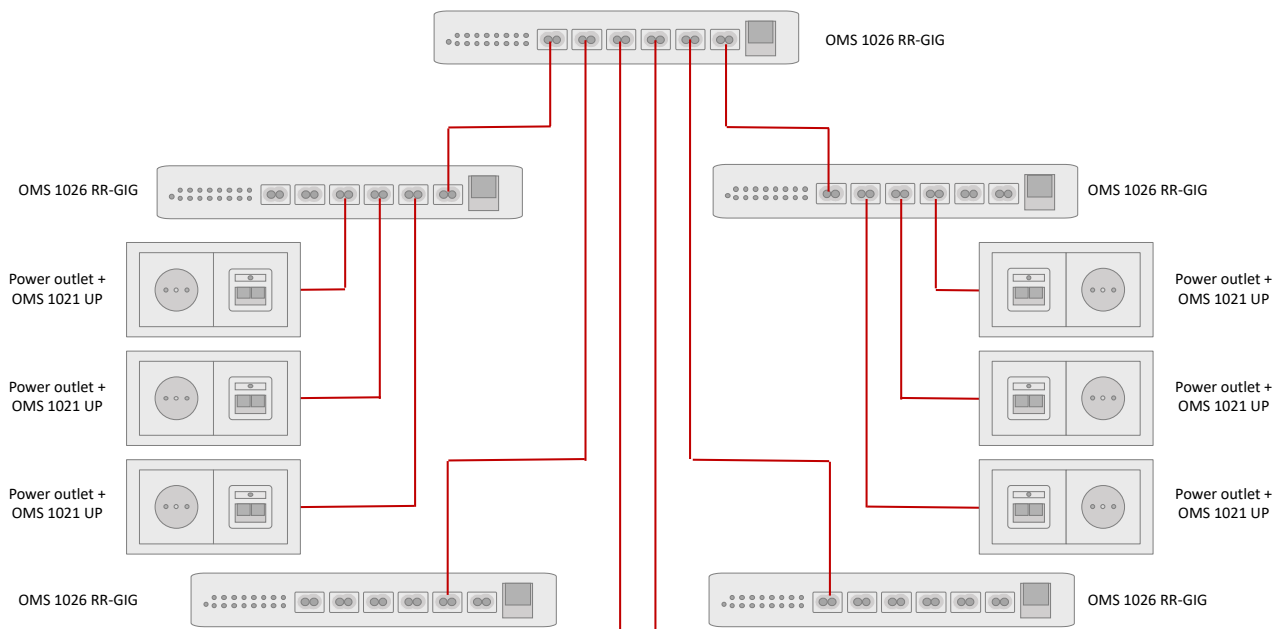

In most cases a switch is not enough for offices and hotels due to the fact that a lot more network connections are required. With the Homefibre switches it is possible to use multiple switches in a row, called cascading, which gives you the opportunity to provide many additional interfaces and longer transmission distances.

Advanced network solutions

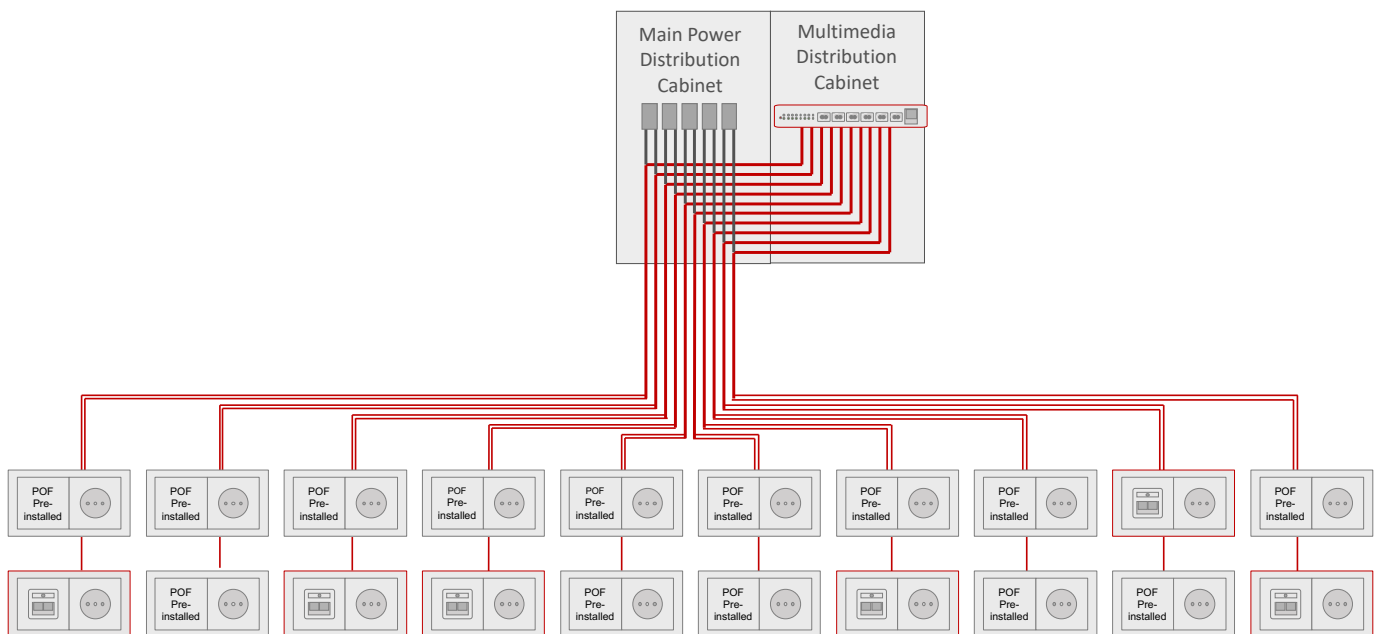

This advanced network architecture shows multiple power outlets pre-installed with POF fibre, some equipped with active data outlets. This wiring system allows flexible installation of WiFi clusters and/or LAN data outlets. The Gigabit POF cable is available everywhere.

The network can be adapted to the requirement of the user. Depending on the number of active data outlets, switches with related number of POF ports can be installed.

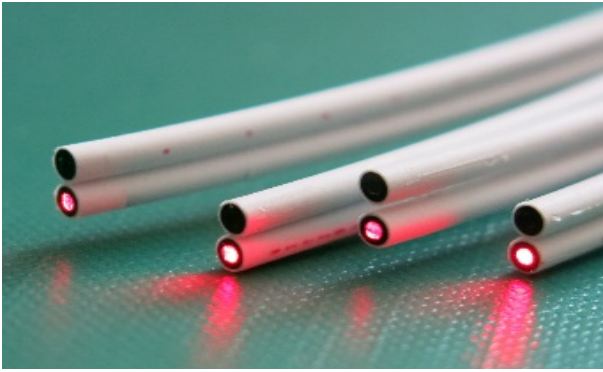

THE OPTICAL CABLE

The Polymer Optical Fibre, also called POF, is approved and has been used in industry and the automotive industry as well as for lightning issues and more. The POF cable is a duplex cable with two fibres, which means that one fibre is used for transmitting and the other fibre is used for receiving optical signals. This increases the transmission length and raises transmission quality and bandwidth. The optical cable may be placed next to electrical wires due to their galvanic non-conduciveness and independency to electromagnetic fields.

The Homefibre system uses the well approved Step Index fibre (SI-fibre) for the core fibre. This high quality fibre is made of PMMA (Polmethyl-Methacrylate) which has shown the best specifications for the transmission of visible red light signals.

With "OPTOHOMÉ", a brand by Mitsubishi Rayon, an innovative optical fibre for home and office networks was developed. This product was optimized to high robustness and a long life expectancy. Additionally we also offer a fire retardant cable.

ADVANTAGES

- easy installation
- simple bonding
- small diameter, light weight
- sturdy, safe and free from radiation
- visible light for visual proof of function
- galvanically non-conducting, no lightning issues

ATTENUATION

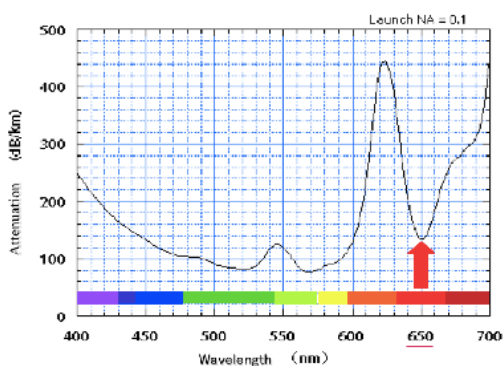

For the Datalight system a wavelength of 650 nm is used. The optical fibre shows a minimum of attenuation at this wavelength. The colors blue, green and yellow might be used in future to optimize the maximum data rate.

MULTIMODE TRANSMISSION

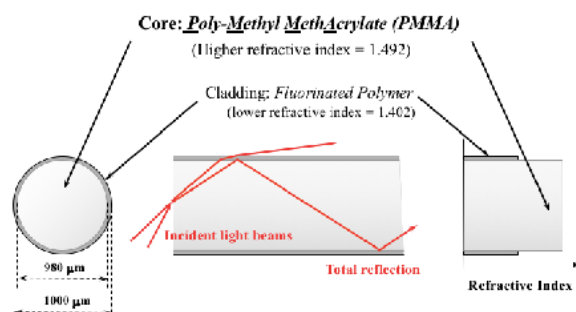

POF is a multimode fibre. The light is reflected on the cladding and is transmitted through the PMMA core. The core diameter of 1mm improves the easy installation. Cutting and plugging are the only two steps necessary to enable transmission.



POF CABLE - FIRE RETARDANT (UL VW-1) WITH POF-UNICUT	POF CABLE REEL	INSTALLATION FLEX TUBE WITH POF AND YE (KOBER)
<p>GHV 4002-G-20 CUT 20 m bundle GHV 4002-G-30 CUT 30 m bundle GHV 4002-G-40 CUT 40 m bundle GHV 4002-G-50 CUT 50 m bundle GHV 4002-G-70 CUT 70 m bundle GHV 4002-G-100 CUT 100 m bundle</p> <p>cladding: Polyvinylchloride cladding core diameter: 980 μm numerical Aperture: 0.5 outer diameter: 2 x 2.2 mm jacketing: grey fire retardant UL VW-1 transmission length: 100 Mbps / 80m * 1 Gbps up to 50 m * with ABR: around 400 Mbps at 80 m operating temperature: -40 °C to 85 °C</p> <p>delivery unit: 20 m, 30 m, 40 m, 50 m, 70 m, 100 m bundle</p> <p><i>ABR = Adaptive Bit Rate</i> * with Homefibre media converters</p>	<p>GHV 4002-G-500 500 m reel GHV 4002-G-1000 1,000 m reel</p> <p>cladding: double Polyethylen cladding core diameter: 980 μm numerical Aperture: 0.5 outer diameter: 2 x 2.2 mm jacketing: grey Fire retardant UL VW-1 transmission length: 100 Mbps / 80 m * 1 Gbps up to 50 m * with ABR: around 400 Mbps at 80 m operating temperature: -40 °C to 85 °C</p> <p>delivery unit: 500 m or 1,000 m reel</p> <p><i>ABR = Adaptive Bit Rate</i> * with Homefibre media converters</p>	<p>FMP 20+3XYE1.5+POF 2.2 pre-wired installation flex tube diameter 20 mm</p> <p>BENEFITS</p> <ul style="list-style-type: none"> • quick and cost saving network wiring combined with electrical installation • customized designs available on request (e.g. YE 1.5 + 2 x POF; coax cable + POF, etc...) • parameter POF cable: see RHEE 4002 or GHV 4002 <p>delivery unit: 50 m bundle</p>

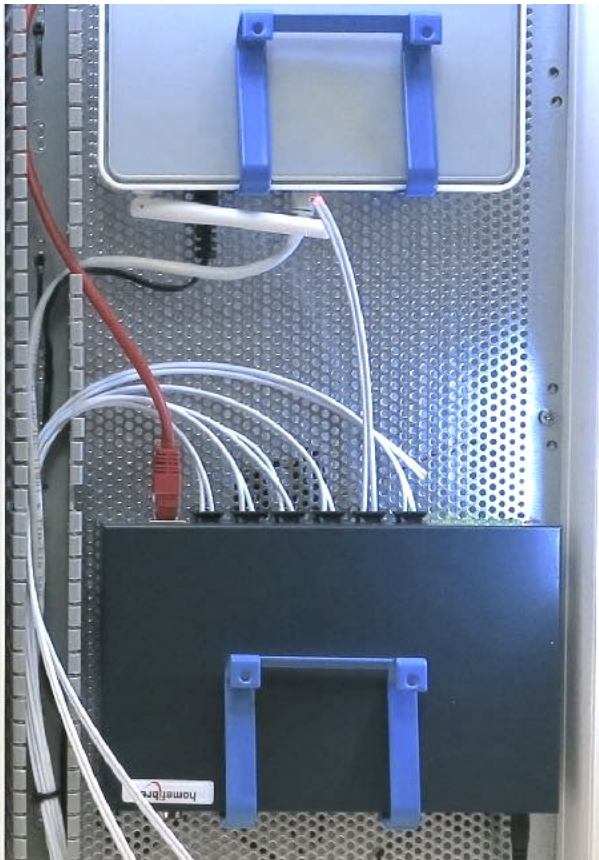

THE OPTICAL SWITCH

Switches are used to connect computer networking devices by using "packet switching" to receive, process and forward data to the terminal device.

The Homefibre optical media switches also include the media converter function. The electrical signal of any copper network is transformed to an optical signal to be then transmitted over the plastic optical fibre (POF).

In a typical home network the switches are used to distribute the network access to the different locations along to the electrical installations. So it is possible to provide a great amount of network connections with gigabit speed.

In this example you can see the OMS 126 RR POF 6+2 port switch connected to an internet access modem via standard CAT 5e patch cable, which allows to distribute the internet access to six different locations.

In home networks it's common that all the multimedia devices are placed in a multimedia distribution cabinet in a spot.

In bigger, more professional networks some network racks can be used in different places.

MAIN POWER AND MULTIMEDIA DISTRIBUTION CABINET



Besides the POF 6+2 port switch the router and a SAT>IP server are also placed beside the main power distribution cabinet in a small multimedia distribution cabinet.

19" NETWORK RACK



In this network rack some POF 12+4 port switches are connected together and so they provide many network connections in the different rooms of this hotel.



**POF 3+1 PORT SWITCH
100 MBPS - FAST ETHERNET**

OMS 113-FC

- 3 x POF port with OPTOLOCK™
- interface for 2.2 mm POF (100 Mbps)
- 1 x RJ45 interface (100 Mbps)

FUNCTIONS

- IEEE 802.3 Ethernet
- IEEE 802.3u Fast Ethernet
- Store and Forward Switching
- 1K MAC address table



**POF 4+1 PORT SWITCH
1 GBPS - GIGABIT ETHERNET**

OMS 1014 ACT-GIG

- 4 x POF port connector less / Broadcom for 2.2 mm POF (1 Gbps)
- 1 x RJ45 interface (1 Gbps)

FUNCTIONS

- IEEE 802.3 Ethernet
- IEEE 802.3u Fast Ethernet
- IEEE 802.3ab Gigabit Ethernet
- Store and Forward Switching
- 8K MAC address table



**POF 6+2 PORT SWITCH
1 GBPS - GIGABIT ETHERNET**

OMS 1026 RR-GIG

- 6 x POF port connector less / Broadcom for 2.2 mm POF (1 Gbps)
- 2 x RJ45 interface (1 Gbps)

FUNCTIONS

- IEEE 802.3 Ethernet
- IEEE 802.3u Fast Ethernet
- IEEE 802.3ab Gigabit Ethernet
- Store and Forward Switching
- 8K MAC address table



**POF 12+4 PORT SMART SWITCH
1 GBPS - GIGABIT ETHERNET**

OMS 1412 RS-GIG

- 12 x POF port connector less / Broadcom for 2.2 mm POF (1 Gbps)
- 2 x RJ45 interface (1 Gbps)
- 2 x SFP+ interface (10 Gbps)

FUNCTIONS

- IEEE 802.3 Ethernet
- IEEE 802.3u Fast Ethernet
- IEEE 802.3ab Gigabit Ethernet
- Store and Forward Switching
- 10K MAC address table
- managed via webinterface and console / SSH

NETWORK SOCKETS & WIFI ACCESS POINTS

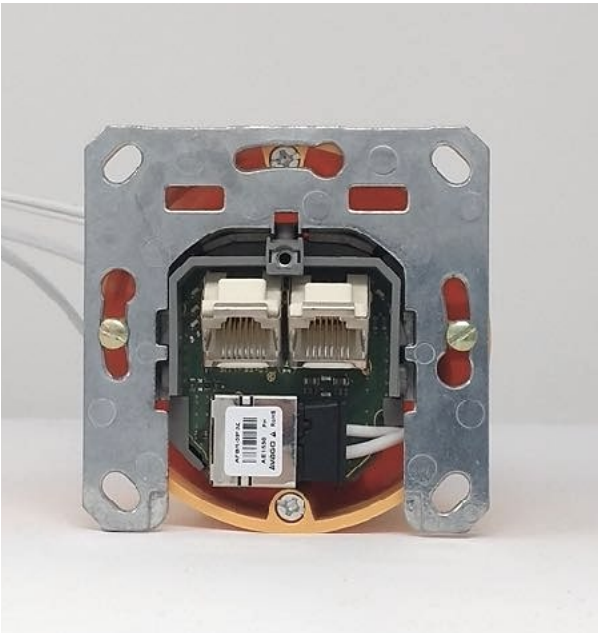

The network sockets are flush-mounted switches which provide two standard RJ45 network interfaces for all kinds of networking devices in different locations.

For mobile devices a flush-mounted optical media WiFi access point is also available. With the access points it is also possible to connect devices without need for a cable.

To provide standard RJ45 connections and electromagnetic fields it is necessary to convert the electrical signals into optical signals. Therefore the active flush-mounted devices and WiFi access points include a media converter function and integrated power supply (100 V - 240 V AC).

All our devices are build with the focus of long durability, energy efficiency and proper temperature management.

The flush-mounted devices are suitable for standard flush-mounted sockets. We also offer adapted solutions for different countries (e.g. Switzerland).

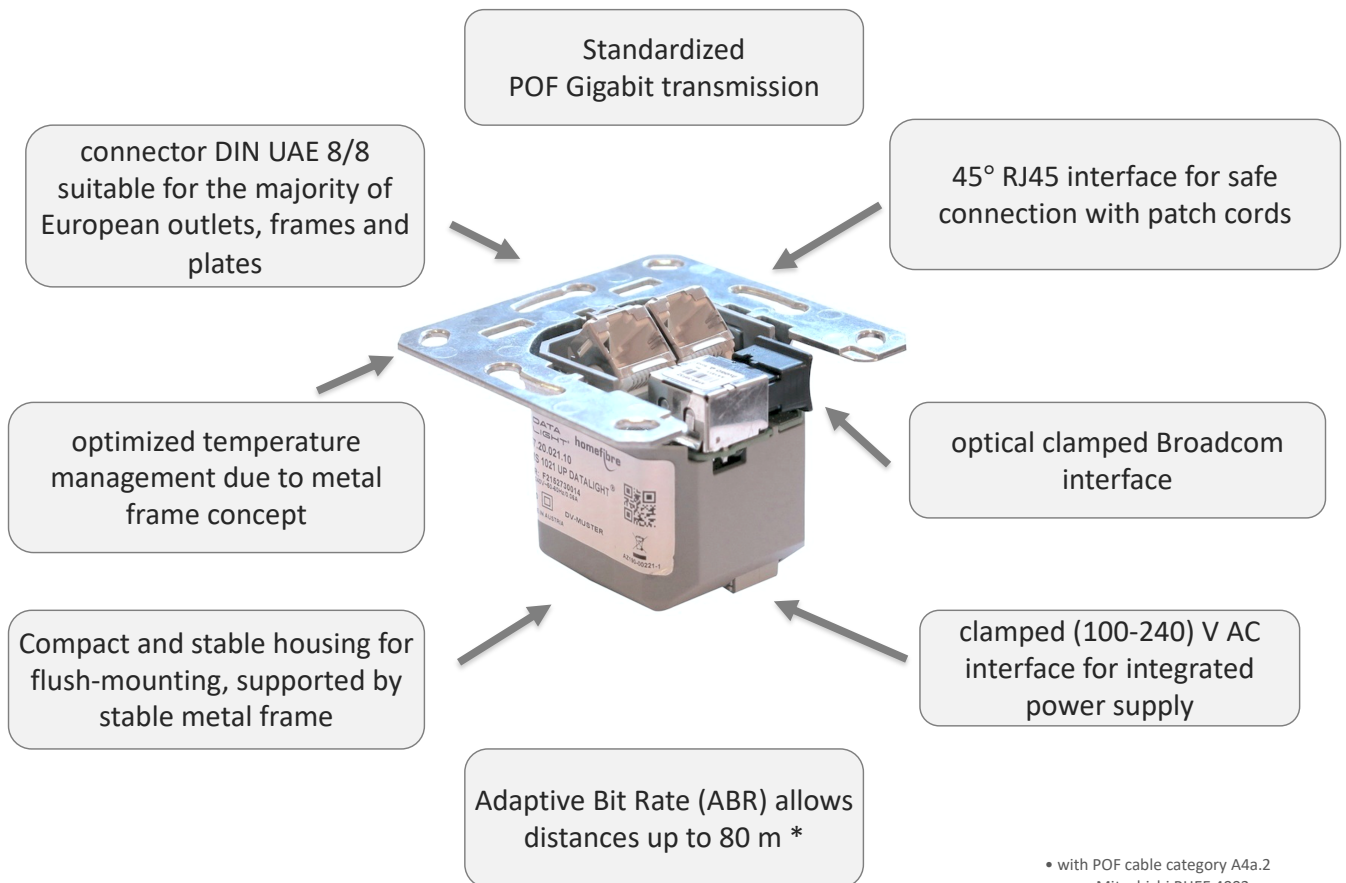

• with POF cable category A4a.2
e.g. Mitsubishi RHEE 4002

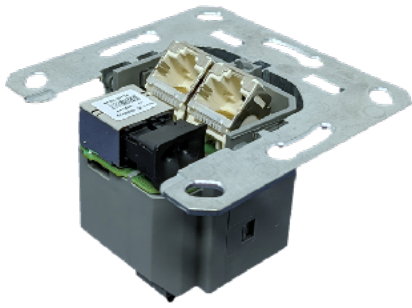

POF NETWORK SOCKET
2 x RJ45 FLUSH-MOUNTED
1 GBPS - GIGABIT ETHERNET

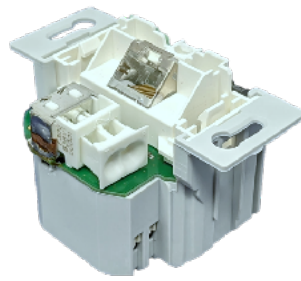

POF WIFI ACCESS POINT
1 x RJ45 FLUSH-MOUNTED
100 MBPS - FAST ETHERNET

OMS 1021 UP

- 1 x POF port connector less / Broadcom for 2.2 mm POF (1 Gbps)
- 2 x RJ45 interface (1 Gbps)

FUNCTIONS

- IEEE 802.3 Ethernet
- IEEE 802.3u Fast Ethernet
- IEEE 802.3ab Gigabit Ethernet
- suitable for standard flush-mounted sockets
- UAE cover plates available from multiple well-known manufacturers

OMA 111 A2 WLAN

- 1 x POF port OPTOLOCK™ interface for 2.2 mm POF (100 Mbps)
- 1 x RJ45 interface (100 Mbps)
- 2 x 2 MiMo WiFi antenna (300 Mbps)

FUNCTIONS

- IEEE 802.3 Ethernet
- IEEE 802.3u Fast Ethernet
- IEEE 802.11n 300 Mbps WiFi 4
- suitable for standard flush-mounted sockets
- UAE cover plates available from multiple well-known manufacturers

INSTALLATION EXAMPLES

MOUNTED IN MAIN POWER SOCKET



IN SURFACE MOUNT FRAME



IN SURFACE CABLE CHANNEL





COUNTRY SPECIFIC SOLUTIONS FOR ITALY

Italian installations are using a different shape of flush-mounting bones and outlets.

To adapt our wall outlets to this shape we offer an adapter system provided by Albrecht Jung GmbH & Co KG.

The adapter system can be ordered from us or directly at them. The necessary order information details are listed in the table below.



ADAPTER WALL FRAME - SOLUTION FOR ITALY

CENTER PLATE FOR ADAPTER FRAME - SOLUTION FOR ITALY

CENTER PLATE FOR ADAPTER FRAME - SOLUTION FOR ITALY

JUNG LSP981 AL-LIT

JUNG LS 969-2

JUNG LS 969-1

With the adapter wall frame the German wall outlets can be used in an Italian in wall installation.

suitable for the adapter wall frame

suitable for the adapter wall frame

- dimensions: 115 mm x 119 mm x 10 mm
- weight: 70 g
- incl. manual

- dimensions: 50 mm x 50 mm x 13 mm
- weight: 18 g
- 1 x RJ45 interface (for OMA111A2 WLAN)

- dimensions: 50 mm x 50 mm x 13 mm
- weight: 16 g
- 2 x RJ45 interfaces (for OMS 1021 UP-GIG)

INSTALLATION EXAMPLE FOR ITALY

**STEP 1:
INSTALL ADAPTER FRAME**



**STEP 2:
INSTALL GERMAN WALL-OUTLET**



**STEP 3:
INSTALL WALL FRAME AND CENTER PLATE**





POF NETWORK SOCKET
2 x RJ45 FLUSH-MOUNTED
1 GBPS - GIGABIT ETHERNET
SWISS VERSION



POF WIFI ACCESS POINT
1 x RJ45 FLUSH-MOUNTED
100 MBPS - FAST ETHERNET
SWISS VERSION

OMS 1021 UP-CH

- 1 x POF port connector less / Broadcom for 2.2 mm POF (1 Gbps)
- 2 x RJ45 interface (1 Gbps)
- inclusive intermediate frame CH and standard center plate UAE 8/8 rw

FUNCTIONS

- IEEE 802.3 Ethernet
- IEEE 802.3u Fast Ethernet
- IEEE 802.3ab Gigabit Ethernet
- suitable for standard flush-mounted sockets in Switzerland
- UAE cover plates available from multiple well-known manufacturers

OMA 111 A2 WLAN-CH

- 1 x POF port with OPTOLOCK™ interface for 2.2 mm POF (100 Mbps)
- 1 x RJ45 interface (100 Mbps)
- 2 x 2 MiMo WiFi antenna (300 Mbps)
- inclusive intermediate frame CH and standard center plate UAE 8 rw

FUNCTIONS

- IEEE 802.3 Ethernet
- IEEE 802.3u Fast Ethernet
- IEEE 802.11n 300 Mbps WiFi
- suitable for standard flush-mounted sockets
- UAE cover plates available from multiple well-known manufacturers

INSTALLATION EXAMPLES FOR SWITZERLAND

MOUNTED IN MAIN POWER SOCKET



IN SURFACE MOUNT FRAME



IN SURFACE CABLE CHANNEL





MEDIA CONVERTERS AND KITS

Media converters convert electrical signals into optical signals and vice versa. With the media converter it is possible to connect a single networking device to the POF network via the standard RJ45 interface.

With the desktop media converter it is easy to set up a point-to-point connection. Therefore the media converter kits include all necessary components.

Beside the point-to-point connection it is also possible to combine the media converter with switches / network sockets. Also multiple common network segments can be connected with an optical link.

Power supply via plug power supply and USB cable. It is also possible to power the media converter via the USB port of a notebook.

POINT-TO-POINT CONNECTION

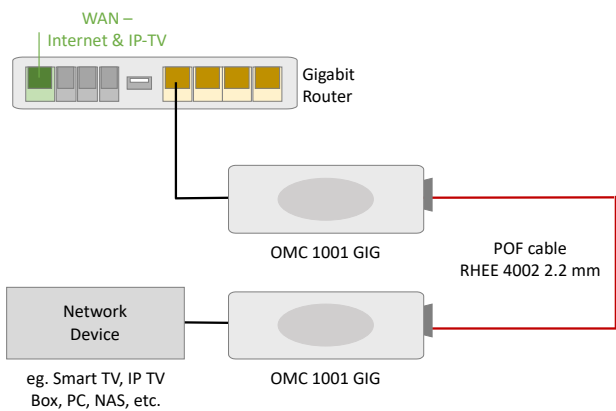

With a media converter set, a network device is connected to the router in this example. The cable, which is only 2.2mm thin, allows it to be laid with electrical installations or along baseboards / under carpets.

CONNECTION TO A NETWORK

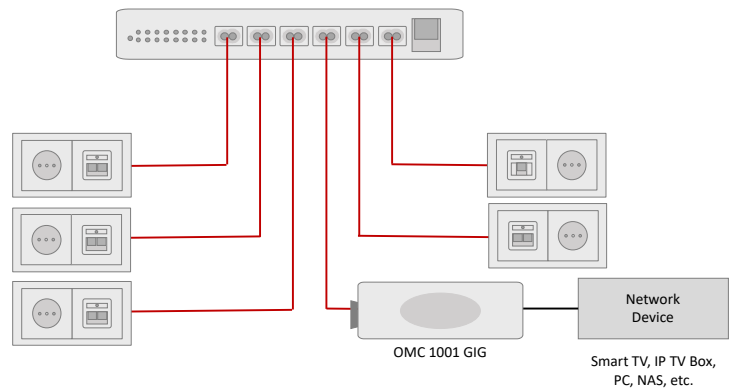

A media converter is used to establish a connection between a POF switch and a network device.



**POF MEDIA CONVERTER
100 MBPS - FAST ETHERNET**

MCE 301-FC

- 1 x POF port with OPTOLOCK™ interface for 2.2 mm POF (100 Mbps)
- 1 x RJ45 interface (100 Mbps)

FUNCTIONS

- can be powered by USB cable
- IEEE 802.3 Ethernet
- IEEE 802.3u Fast Ethernet

includes:

- 1 x MCE 301-FC
- 1 x CAT 5e patch cable
- 1 x power supply
- 1 x USB cable
- 1 x user manual



**POF MEDIA CONVERTER KIT
100 MBPS - FAST ETHERNET**

MCE 301-FC - 30 SI

- incl. 30 m GHV cable bundle

SET INCL.

- 2 x MCE 301-FC
- 2 x power supply
- 2 x USB cable
- 1 x POF cable bundle
- 1 x POF-Unicut
- 2 x CAT 5e patch cable
- 1 x user manual

SAMPLE APPLICATION



**POF MEDIA CONVERTER
1 GBPS - GIGABIT ETHERNET**

OMC 1001 GIG

- 1 x POF port connector less / Broadcom for 2.2 mm POF (1 Gbps)
- 1 x RJ45 interface (1 Gbps)

FUNCTIONS

- Can be powered by USB cable
- IEEE 802.3 Ethernet
- IEEE 802.3u Fast Ethernet
- IEEE 802.3ab Gigabit Ethernet

includes:

- 1 x OMC 1001 GIG
- 1 x CAT 5e patch cable
- 1 x power supply
- 1 x USB cable
- 1 x user manual



**POF MEDIA CONVERTER KIT
1 GBPS - GIGABIT ETHERNET**

- **OMC 1001 GIG - 20 SI** (incl. 20 m POF)
- **OMC 1001 GIG - 30 SI** (incl. 30 m POF)
- **OMC 1001 GIG - 40 SI** (incl. 40 m POF)
- **OMC 1001 GIG - 50 SI** (incl. 50 m POF)

SET INCL.

- 2 x OMC 1001 GIG
- 2 x power supply
- 2 x USB cable
- 1 x POF cable bundle
- 1 x POF-Unicut
- 2 x CAT 5e patch cable
- 1 x user manual

SAMPLE APPLICATION

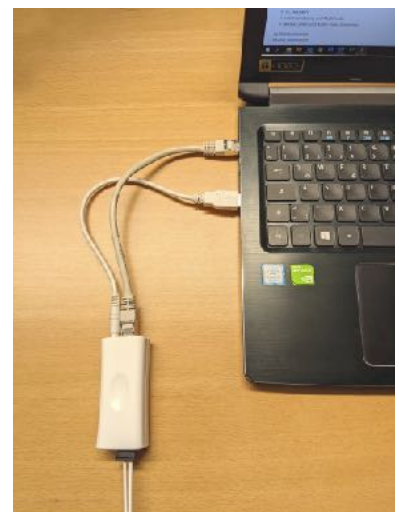

MEDIA CONVERTER WITH SWITCHING TECHNOLOGY

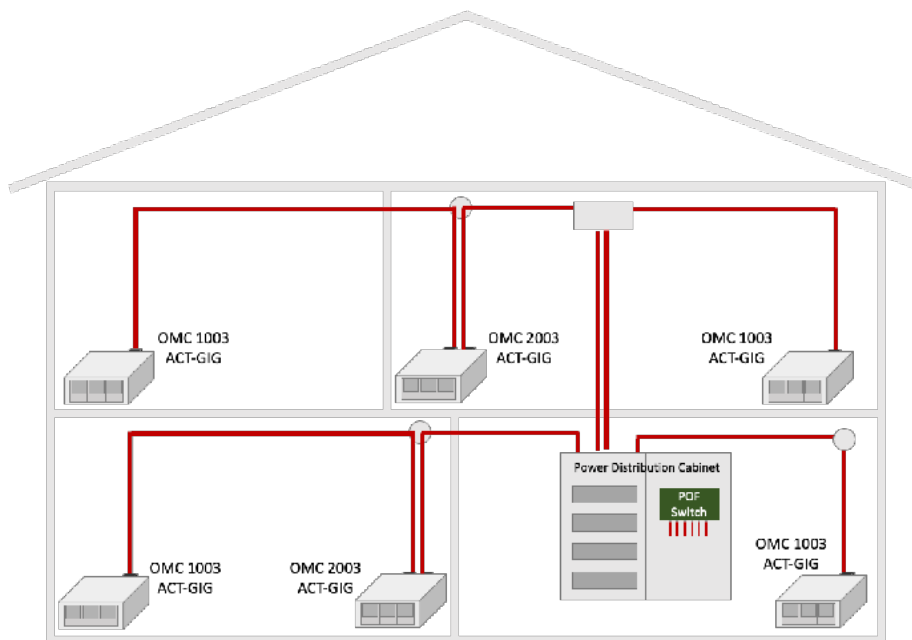

These devices offer the possibility to integrate several devices simultaneously into a POF network. The ports are interconnected like a typical switch.

The version with two POF ports offers the possibility not to let your POF network end at this point, but to continue to an additional segment.



POF 2+3 PORT MEDIA CONVERTER 1 GBPS - GIGABIT ETHERNET	POF 1+3 PORT MEDIA CONVERTER 1 GBPS - GIGABIT ETHERNET	SAMPLE APPLICATION
<p>OMC 2003 ACT-GIG</p> <ul style="list-style-type: none"> • 2 x POF port connector less / Broadcom for 2.2 mm POF (1 Gbps) • 3 x RJ45 interface (1 Gbps) <p>FUNCTIONS</p> <ul style="list-style-type: none"> • Can be powered by USB cable • IEEE 802.3 Ethernet • IEEE 802.3u Fast Ethernet • IEEE 802.3ab Gigabit Ethernet <p>includes:</p> <ul style="list-style-type: none"> • 1 x OMC 2003 ACT-GIG • 1 x power supply • 1 x USB cable • 1 x user manual 	<p>OMC 1003 ACT-GIG</p> <ul style="list-style-type: none"> • 1 x POF port connector less / Broadcom for 2.2 mm POF (1 Gbps) • 3 x RJ45 interface (1 Gbps) <p>FUNCTIONS</p> <ul style="list-style-type: none"> • Can be powered by USB cable • IEEE 802.3 Ethernet • IEEE 802.3u Fast Ethernet • IEEE 802.3ab Gigabit Ethernet <p>includes:</p> <ul style="list-style-type: none"> • 1 x OMC 2003 ACT-GIG • 1 x power supply • 1 x USB cable • 1 x user manual 	

DIN RAIL MOUNTED MEDIA CONVERTER

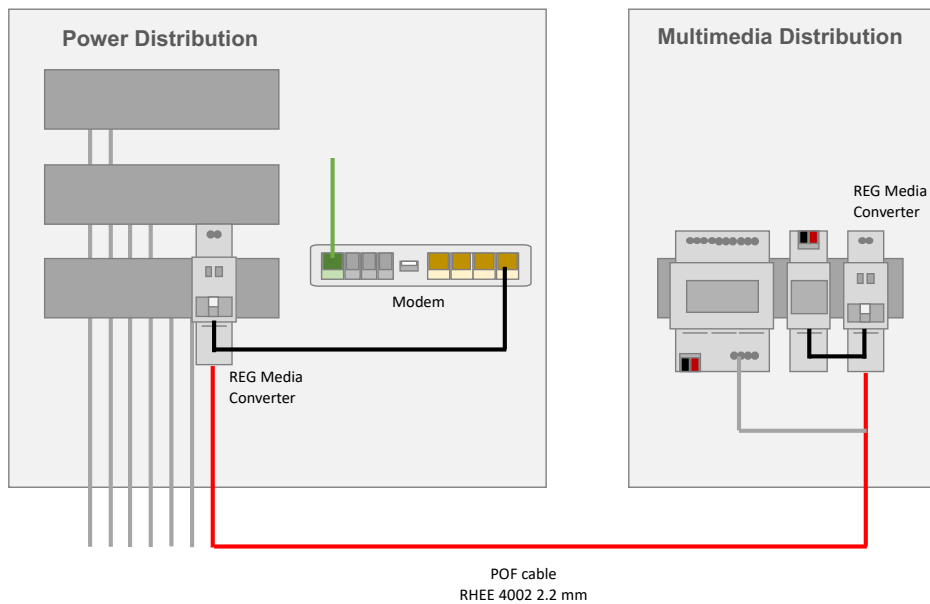

For Smart Home applications or for the combination with the electrical installation, media converters for DIN rail mounting are preferred.

These can be used in distribution cabinets and offer a standardized RJ45 network connection for smart home controls, for example.



POF DIN RAIL MOUNTED MEDIA CONVERTER 100 MBPS - FAST ETHERNET

OMC 100 REG

- 1 x POF port with OPTOLOCK™ interface for 2.2 mm POF (100 Mbps)
- 1 x RJ45 interface (100 Mbps)

FUNCTIONS

- for DIN rail mounting
- IEEE 802.3 Ethernet
- IEEE 802.3u Fast Ethernet

POF DIN RAIL MOUNTED MEDIA CONVERTER 1 GBPS - GIGABIT ETHERNET

OMC 1000 REG-GIG

- 1 x POF port connector less interface for 2.2 mm POF (1 Gbps)
- 1 x RJ45 interface (1 Gbps)

FUNCTIONS

- for DIN rail mounting
- IEEE 802.3 Ethernet
- IEEE 802.3u Fast Ethernet
- IEEE 802.3ab Gigabit Ethernet

INSTALLATION EXAMPLE





TOOLS

The thin POF cable can be installed in one conduit together with the electrical wiring, behind the skirting board or under the carpet. This method offers cost savings, less installation work and maximum safety and efficiency. A safe broadband port can thus be created at any main plug socket in your home or office within a minimum of time.

To guarantee the best POF connection, a clean and smooth cut of the cable ends is essential. Different cutting tools are available.

For optical quality and function control of POF links we offer optical measurement tools.

The tools described here simplify the installation and testing of the optical POF network.



POF CUTTER

POF CONNECTING TOOL

POF OPTICAL POWER METER

<p>POF-UNICUT simple cutting tool for POF cable</p>	<p>POF 600 004-2-3 tool with cutting system and stripping aid length: 190 mm weight: 505 g material: special tool steel</p>	<p>OPM 650 photodetector: 2.2 mm POF interface wavelength: 650 nm metering range: -35 dBm up to +10 dBm operating temperature: -10 °C to +50 °C dimensions: 165 mm x 80 mm x 50 mm</p>
<p>FUNCTIONS</p> <ul style="list-style-type: none"> • Tool for clean cutting of the POF-cable and easy installation of the connector less ports and POF-transceiver. 	<p>FUNCTIONS</p> <ul style="list-style-type: none"> • with cutting system for cutting and stripping off 2.2 mm POF cable • stripping free of damage, exact adjustment of cable • exact cut surface by special cutting system • no polishing of cut surface necessary, immediate subsequent treatment possible • bronzed with two-component handle bars 	<p>FUNCTIONS</p> <ul style="list-style-type: none"> • optical power measurement • storage and uploading of up to 1,000 measurements to the PC • evaluation software supports test reporting

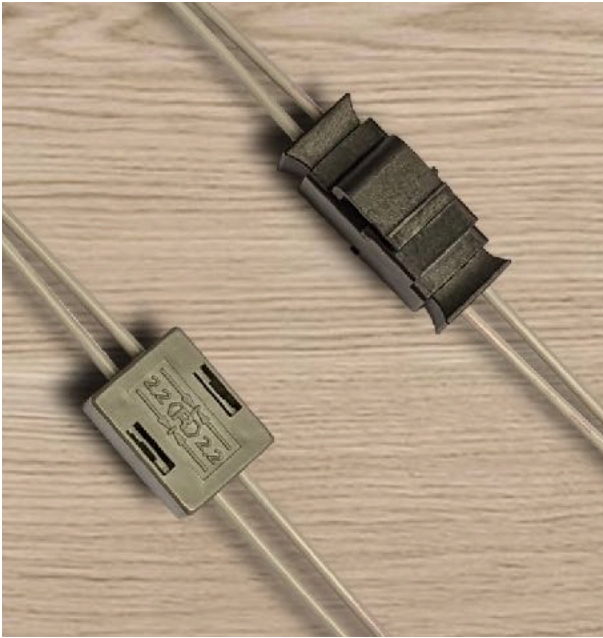

CONNECTORS

With a connector it is possible to lengthen the connection or in case of damage of the cable to cut the damaged part and connect the ends with it.

Note: The use of connectors decreases the maximum transmission length.



POF CONNECTOR 2.2 MM



POF CONNECTOR 1.5 MM / 2.2 MM



POF OL-OL KEYSTONE - CONNECTOR MODULE

<p>POF-VB 2.2 MM color: grey</p> <p>connector-less connector for POF cable 2.2 mm attenuation: approx. 2.5 dBm</p>	<p>POF-VB 1.5 / 2.2 color: black</p> <p>connector-less connector for pof cable 1.5 mm to 2.2 mm attenuation: approx. 2.5 dBm</p>	<p>POF OLOL KS color: black</p> <p>connector with 2 x Optolock interfaces for POF cable 2.2 mm attenuation: approx. 2.5 dBm</p>
---	---	--



SMI ADAPTER

A passive POF interface (connector) offers a low-cost optical interface. This kind of interface can be used to change a connected link e.g. in combination with a media converter. Often times a mounting frame is also used so that the pre-installed cable can be easily spotted by the future tenant. If necessary, the mounting frame can be replaced by a flush-mounted switch or WiFi access point.



**MOUNTING FRAME FOR
KEYSTONE MODULS**

KMK MA-UP RW ; 105 313 03
mounting frame for 1 or 2 Keystone modules
dimensions: 70 mm x 70 mm x 17 mm



**POF OL-SMI KEYSTONE -
SMI INTERFACE MODULE**

POF OL-SMI KS
color: black

connector with 1 x Optolock interface and
SMI Interface for POF cable 2.2 mm
attenuation: approx. 2.5 dBm



POF SMI PATCHCABLE 1.5M

POF SMI PC 1.5m
POF SMI Connector with 1.5 m POF cable
for connection between e.g Media Converter
and optical data outlet

core diameter: 1 mm
outside diameter: 2.2 mm

**PLUG-ON
OL-SMI KEYSTONE MODULE**

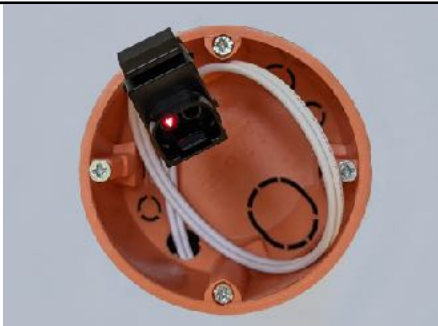

**FIX THE KEYSTONE MODULE
WITH THE MOUNTING FRAME**

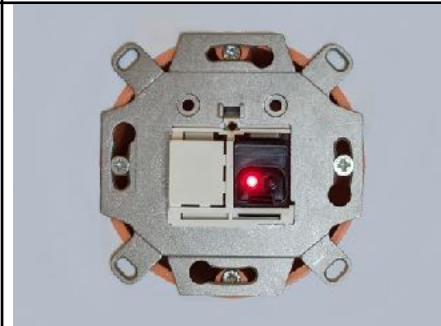

POF SMI INTERFACE WITH COVER



PASSIVE PRE-INSTALLATION WITH SMI INTERFACE

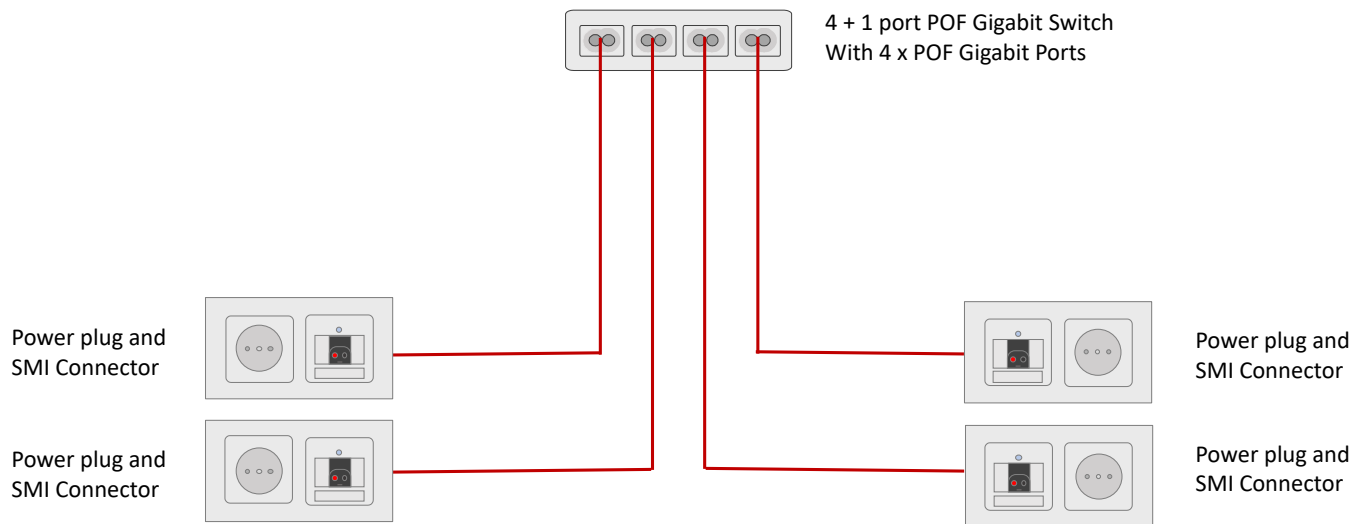

In order to make network connections retrofittable for the future, it is also possible to carry out a passive pre-installation. It offers the possibility of flexibly installing a network and expanding it as required.

Already installed SMI connections can be activated by a media converter or replaced by a network socket with RJ45 connections or with Wifi.

PRE-INSTALLATION IN MULTIMEDIA DISTRIBUTION

SMI CONNECTION WITH MEDIA CONVERTER

REPLACE SMI INTERFACE WITH NETWORK SOCKET



The POF cables are parked. To activate, the parked cables are connected to a switch.

On the SMI interface any type of media converter or switch can be used with the POF SMI patch cable.

Through clever installation, the SMI interface can be exchanged at any time with a network socket with RJ45 connections or Wifi.



ACCESSORIES

Our switches are made for placement on desks. With the accessories they can be used in many different ways.

For example it is possible to install the POF 6+2 port switch in a 19" rack or place them in the multimedia distribution cabinet.

The Switch Mounting can be used for all kinds of smaller devices which should be installed on a hole plate in a multimedia distribution cabinet or on DIN rail.



19" RACK SHELF

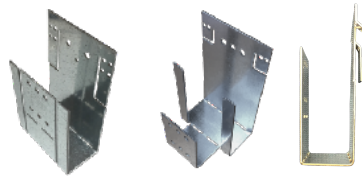

SWITCH MOUNTING FOR MULTIMEDIA DISTRIBUTION CABINET

SAMPLE APPLICATION

19" RACK

for up to 2 x OMS 126 RR or
2 x OMS 1026 RR-GIG
dimensions: 48.3 cm x 12 cm x 4.5 cm (1U)

weight: 472 g
color: galvanized

- rack Shelf for the installation of max. 2 x POF 6+2 Port Switches in 19" rack
- incl. mounting screws

HOS2

for up to 2 x Optical Media Switches
dimensions: 22.5 cm x 7 cm x 0.1 cm (raw)
11 cm x 7 cm x 6.5 cm (bended)

weight: 90 g
color: galvanized

- mounting solution for optical media switches in an multimedia distribution cabinet
- rail mounting possible
- mounting on mounting plate possible





The flush-mounted devices are manufactured in compliance with international standards; hence all frames and plates are available from all leading manufactures.

Due to our close cooperation with Rutenbeck it is possible to offer the standard frames and covers as listed below.



WALL PLATE

STANDARD CENTER PLATE WITH LABELING FIELD - 1 x RJ45 PLUG

STANDARD CENTER PLATE WITH LABELING FIELD - 2 x RJ45 PLUGS

AP RW ; 100 100 51
color: similar RAL 9010; pure white

ZST UAE 8 RW ; 130 100 52
color: similar RAL 9010; pure white

ZST UAE 8/8 RW ; 130 100 53
color: similar RAL 9010; pure white

dimensions: 80 mm x 80 mm x 5 mm
weight: 12 g

dimensions: 50 mm x 50 mm x 13 mm
weight: 6 g
1 x RJ45 interface (e.g. OMA 111 A2 WLAN)

dimensions: 50 mm x 50 mm x 13 mm
weight: 6 g
2 x RJ45 interfaces (OMS 1021 UP-GIG)



SURFACE MOUNTED HOUSING

INTERMEDIATE FRAME CH

CENTER PLATE FOR KEYSTONE MOUNTING FRAME

UAE-6APG RW; 135 115 03
color: similar RAL 9010; pure white

ADAPTER FRAME SWISS
color: similar RAL 9010; pure white

ZST UM-MA 2 RW; 139 100 03
center plate for 2 modules, pure white

dimensions: 80 mm x 80 mm x 46 mm
weight: 93 g

dimension: 60 mm x 60 mm
weight: 3 g
for Swiss modified version

dimension: 50 mm x 50 mm
weight: 6 g
for Keystone

SPECIFICATION - OPTICAL CABLE

PARAMETER	RHEE 4002	GHV 4002
Fibre		
Core Material	Polymethyl-Methacrylate Resin (PMMA)	
Cladding	Flourinated Polymer	
Core Refractive Index	1.49	
Refractive Index Profile	Step Index	
Numerical Aperture (NA)	0.5	
Core diameter in μm	Min. 920 / typ. 980 / Max. 1040	
Diameter with Cladding in μm	Min. 940 / typ. 1000 / Max. 1060	
Jacket		
Material	Polyethylene, double jacketing	Polyvinylchloride
Color	white	grey
Dimension in mm	Minor Achse - Min. 2.13 / typ. 2.2 / Max. 2.27 Major Achse - Min. 4.3 / typ. 4.4 / Max. 4.5	
Fibre identification	One fibre of the duplex cable has the following indication in pink: "ESKA OPTOHOME MITSUBISHI RAYON"	One fibre of the duplex cable has the following indication in pink: "MITSUBISHI Chemical AWM 5238 80C VW-1 GHV 4002"
Weight	approx. 7.5 g/m	approx. 11 g/m
Bundle	20 m, 30 m, 40 m, 50 m, 70 m, 100 m	20 m, 30 m, 40 m, 50 m, 70 m, 100 m
Reel	500 m, 1,000 m	500 m, 1,000 m
Characteristics	low cost, no light leakage on bendings	fire retardant, UL VW-1
Mechanics		
Operating temperature	-55 °C to +70 °C (in dry climate) max. 60 °C (up to 95 % humidity)	-40 °C to +85 °C (in dry climate) max. 75 °C (up to 95 % humidity)
Transmission losses	170 dB/km (at 650 nm)	
Minimum bend radius	Loss \leq 0.5 dB 25 mm @100 % transmission (quarter bending)	
Tensile strength	Tensile force @ 5 % elongation: 140 N	
Compression (at 50kg weight)	0.4 dB increasing of attenuation	
Standard	IEC 60793-2-40 Optical fibres -Part 2-40	

SPECIFICATION - FAST ETHERNET MEDIA CONVERTER

Device	MCE 301-FC	OMC 100 REG
Standard	IEEE 802.3, IEEE 802.3u, IEEE 802.3x	IEEE 802.3, IEEE 802.3u
QoS		
Accreditation	FCC Part 15 Class B, EN 55022 Class B	FCC Part 15 Class B, EN 55022 Class B
Optical network interface	1 x OPTOLOCK interface	1 x OPTOLOCK interface
Information rate optical interface	100 Mbps	100 Mbps
Wavelength	650 nm	650 nm
Optical Gigabit input sensitivity		
Optical Gigabit transmission distance		
Backward compatibility		
Optical 100 Mbps input sensitivity	-23 dBm	-23 dBm
Optical 100 Mbps transmission distance	typ. 80 m ¹	typ. 80 m ¹
Network interface	1 x RJ45	1 x RJ45
Information rate network interface	100 Mbps	100 Mbps
Network interface transmission distance	100 m	100 m
Additional network interface		
Additional network interface transmission distance		
Information rate additional network interface		
Power supply	5 V DC 0.4 A ext. power supply; (100 - 240) V AC (50 - 60) Hz	(8 - 24) V DC ext. power supply; not included!
Power consumption typ.	0.9 W	0.9 W
Operation temperature	0 °C to +45 °C	-5 °C to +45 °C
Protecting Class DIN EN 60529	IP20	IP20
Protecting Class DIN EN 61140	II	II
Dimensions (WxHxD) in mm	40 x 93,5 x 25,2	70 x 90 x 18
Application	home and office networks	include smart home devices, DIN rail mounting devices

¹ with recommended POF cable: SI faser, NA: 0.5; Cat. A4a.2
(z.B. Mitsubishi Optohome RHEE 4002, GHV 4002)

SPECIFICATION - GIGABIT MEDIA CONVERTER

Device	OMC 1001 GIG	OMC 1000 REG-GIG
Standard	IEEE 802.3, IEEE 802.3u, IEEE 802.3ab	IEEE 802.3, IEEE 802.3u, IEEE 802.3ab
QoS		
Accreditation	FCC Part 15 Class B, EN 55022 Class B	FCC Part 15 Class B, EN 55022 Class B
Optical network interface	1 x POF connector less Broadcom	1 x POF connector less Broadcom
Information rate optical interface	1 Gbps	1 Gbps
Wavelength	650 nm	650 nm
Optical Gigabit input sensitivity	-16.5 dBm	-16.5 dBm
Optical Gigabit transmission distance	typ. 50 m ¹ up to 80 m with ABR ²	typ. 50 m ¹ up to 80 m with ABR ²
Backward compatibility	Yes	Yes
Optical 100 Mbps input sensitivity	-23 dBm	-23 dBm
Optical 100 Mbps transmission distance	typ. 80 m ¹	typ. 80 m ¹
Network interface	1 x RJ45	1 x RJ45
Information rate network interface	1 Gbps	1 Gbps
Network interface transmission distance	100 m	100 m
Additional network interface		
Additional network interface transmission distance		
Information rate additional network interface		
Power supply	5 V DC 1.2 A ext. power supply; (100 - 240) V AC (50 - 60) Hz	(8 - 52) V DC ext. power supply; not included!
Power consumption typ.	1.3 W	1.9 W
Operation temperature	0 °C to +45 °C	-5 °C to +45 °C
Protecting Class DIN EN 60529	IP20	IP20
Protecting Class DIN EN 61140	II	II
Dimensions (WxHxD) in mm	35 x 90 x 18	70 x 90 x 18
Application	home and office networks	include smart home devices, DIN rail mounting devices

¹ with recommended POF cable: SI faser, NA: 0.5; Cat. A4a.2
(z.B. Mitsubishi Optohome RHEE 4002, GHV 4002)

² ABR means Adaptive Bit Rate. The reduction of the information rate is used for guarantee error free transmission if the signal strength is low or the length of the cable is above 50 m

SPECIFICATION - MEDIA CONVERTER WITH SWITCHING FUNCTION

Device	OMC 1003 ACT-GIG	OMC 2003 ACT-GIG
Standard	IEEE 802.3, IEEE 802.3u, IEEE 802.3ab	IEEE 802.3, IEEE 802.3u, IEEE 802.3ab
QoS		
Accreditation	FCC Part 15 Class B, EN 55022 Class B	FCC Part 15 Class B, EN 55022 Class B
Optical network interface	1 x POF connector less Broadcom	2 x POF connector less Broadcom
Information rate optical interface	1 Gbps	1 Gbps
Wavelength	650 nm	650 nm
Optical Gigabit input sensitivity	-16.5 dBm	-16.5 dBm
Optical Gigabit transmission distance	typ. 50 m ¹	typ. 50 m ¹
Backward compatibility	Yes	Yes
Optical 100 Mbps input sensitivity	-23 dBm	-23 dBm
Optical 100 Mbps transmission distance	typ. 80 m ¹	typ. 80 m ¹
Network interface	3 x RJ45	3 x RJ45
Information rate network interface	1 Gbps	1 Gbps
Network interface transmission distance	100 m	100 m
Additional network interface		
Additional network interface transmission distance		
Information rate additional network interface		
Power supply	5 V DC 1.2 A ext. power supply; (100 - 240) V AC (50 - 60) Hz	5 V DC 1.2 A ext. power supply; (100 - 240) V AC (50 - 60) Hz
Power consumption typ.	2.8 W	3 W
Operation temperature	0 °C to +45 °C	0 °C to +45 °C
Protecting Class DIN EN 60529	IP20	IP20
Protecting Class DIN EN 61140	II	II
Dimensions (WxHxD) in mm	66 x 90 x 25	66 x 90 x 25
Application	home and office networks	home and office networks

¹ with recommended POF cable: SI faser, NA: 0.5; Cat. A4a.2
(z.B. Mitsubishi Optohome RHEE 4002, GHV 4002)

SPECIFICATION - FAST ETHERNET SWITCH

Device	OMS 113-FC
Standard	IEEE 802.3, IEEE 802.3u
QoS	
Accreditation	FCC Part 15 Class B, EN 55022 Class B
Optical network interface	3 x OPTOLOCK interface
Information rate optical interfaces	100 Mbps
Wavelength	650 nm
Optical Gigabit input sensitivity	
Optical Gigabit transmission distance	
Backward compatibility	
Optical 100 Mbps input sensitivity	-23 dBm
Optical 100 Mbps transmission distance	typ. 80 m ¹
Network interface	1 x RJ45
Information rate network interface	100 Mbps
Network interface transmission distance	100 m
Additional network interface	
Additional network interface transmission distance	
Information rate additional network interface	
Power supply	5 V DC 2 A ext. power supply; (100 - 240) V AC (50 - 60) Hz
Power consumption typ.	
Operation temperature	0 °C to +50 °C
Protecting Class DIN EN 60529	IP20
Protecting Class DIN EN 61140	II
Dimensions (WxHxD) in mm	
Application	small home and office networks

¹ with recommended POF cable: SI faser, NA: 0.5; Cat. A4a.2
(z.B. Mitsubishi Optohome RHEE 4002, GHV 4002)

SPECIFICATION - GIGABIT SWITCH

Device	OMS 1041 ACT-GIG	OMS 1026 RR-GIG	OMS 1412 RS-GIG
Standard	IEEE 802.3, IEEE 802.3u, IEEE 802.3ab	IEEE 802.3, IEEE 802.3u, IEEE 802.3ab	IEEE 802.3, IEEE 802.3u, IEEE 802.3ab
QoS			Web configuration, console
Accreditation	FCC Part 15 Class B, EN 55022 Class B	FCC Part 15 Class B, EN 55022 Class B	FCC Part 15 Class B, EN 55022 Class B
Optical network interface	4 x POF connector less Broadcom	6 x POF connector less Broadcom	12 x POF connector less Broadcom
Information rate optical interfaces	1 Gbps	1 Gbps	1 Gbps
Wavelength	650 nm	650 nm	650 nm
Optical Gigabit input sensitivity	-16.5 dBm	-16.5 dBm	-16.5 dBm
Optical Gigabit transmission distance	typ. 50 m ¹ up to 80 m with ABR ²	typ. 50 m ¹ up to 80 m with ABR ²	typ. 50 m ¹ up to 80 m with ABR ²
Backward compatibility	Yes	Yes	Yes
Optical 100 Mbps input sensitivity	-23 dBm	-23 dBm	-23 dBm
Optical 100 Mbps transmission distance	typ. 80 m ¹	typ. 80 m ¹	typ. 80 m ¹
Network interface	1 x RJ45	2 x RJ45	2 x RJ45
Information rate network interface	1 Gbps	1 Gbps	1 Gbps
Network interface transmission distance	100 m	100 m	100 m
Additional network interface			2 x SFP+
Additional network interface transmission distance			10 Gbps
Information rate additional network interface			100 m / 1 km
Power supply	12 V DC 0.5 A ext. power supply; (100-240) V AC (50-60) Hz	5 V DC 3 A ext. power supply; (100-240) V AC (50-60) Hz	12 V DC 3 A ext. power supply; (100-240) V AC (50-60) Hz
Power consumption typ.	6 W	10 W	15 W
Operation temperature	0 °C to +42 °C	0 °C to +42 °C	0 °C to +42 °C
Protecting Class DIN EN 60529	IP20	IP20	IP20
Protecting Class DIN EN 61140	II	II	II
Dimensions (WxHxD) in mm	90 x 80 x 24.5	196 x 30 x 124	440 x 45 x 210 (19" Switch, 1U)
Application	small home and office networks	home and office networks	complex networks

¹ with recommended POF cable: SI faser, NA: 0.5; Cat. A4a.2
(z.B. Mitsubishi Optohome RHEE 4002, GHV 4002)

² ABR means Adaptive Bit Rate. The reduction of the information rate is used for guarantee error free transmission if the signal strength is low or the length of the cable is above 50 m

SPECIFICATION - NETWORK SOCKETS

Device	OMS 121 UP (CH)	OMS 1021 UP-GIG (CH)
Standard	IEEE 802.3, IEEE 802.3u	IEEE 802.3, IEEE 802.3u, IEEE 802.3ab
QoS		
Accreditation	FCC Part 15 Class B, EN 55022 Class B	FCC Part 15 Class B, EN 55022 Class B
Optical network interface	1 x OPTOLOCK interface	1 x POF connector less Broadcom
Information rate optical interface	100 Mbps	1 Gbps
Wavelength	650 nm	650 nm
Optical Gigabit input sensitivity		-16.5 dBm
Optical Gigabit transmission distance		typ. 50 m ¹ up to 80 m with ABR ²
Backward compatibility		Yes
Optical 100 Mbps input sensitivity	-23 dBm	-23 dBm
Optical 100 Mbps transmission distance	typ. 80 m ¹	typ. 80 m ¹
Network interface	2 x RJ45	2 x RJ45
Information rate network interface	100 Mbps	1 Gbps
Network interface transmission distance	100 m	100 m
Additional network interface		
Additional network interface transmission distance		
Information rate additional network interface		
Power supply	integrated power supply; (100 - 240) V AC (50 - 60) Hz	integrated power supply; (100 - 240) V AC (50 - 60) Hz
Power consumption typ.	0.9 W	2.8 W
Operation temperature	-5 °C to +45 °C	0 °C to +45 °C
Protecting Class DIN EN 60529	IP20	IP20
Protecting Class DIN EN 61140	II	II
Dimensions (WxHxD) in mm	fits to DIN Flush-mounting boxes	fits to DIN Flush-mounting boxes
Application	home and office networks	home, office and complex networks

¹ with recommended POF cable: SI faser, NA: 0.5; Cat. A4a.2
(z.B. Mitsubishi Optohome RHEE 4002, GHV 4002)

² ABR means Adaptive Bit Rate. The reduction of the information rate is used for guarantee error free transmission if the signal strength is low or the length of the cable is above 50 m

SPECIFICATION - WIFI ACCESS POINT

Device	OMA 111 A2 WLAN (CH)
Standard	IEEE 802.3, IEEE 802.3u, IEEE 802.11n
QoS	Web configuration
Accreditation	FCC Part 15 Class B, EN 55022 Class B
Optical network interface	1 x OPTOLOCK interface
Information rate optical interface	100 Mbps
Wavelength	650 nm
Optical Gigabit input sensitivity	
Optical Gigabit transmission distance	
Backward compatibility	
Optical 100 Mbps input sensitivity	-23 dBm
Optical 100 Mbps transmission distance	typ. 80 m ¹
Network interface	1 x RJ45
Information rate network interface	100 Mbps
Network interface transmission distance	100 m
Additional network interface	1 x WiFi antenna 2.4 GHz
Additional network interface transmission distance	Very good: typ. (5 - 10) m Accaptable: typ. (10 - 20) m
Information rate additional network interface	300 Mbps (WiFi 4)
Power supply	integrated power supply; (100 - 240) V AC (50 - 60) Hz
Power consumption typ.	< 3.9 W
Operation temperature	-5 °C to +35 °C
Protecting Class DIN EN 60529	IP20
Protecting Class DIN EN 61140	II
Dimensions (WxHxD) in mm	fits to DIN flush-mounting boxes
Application	home networks with small number of clients

¹ with recommended POF cable: SI faser, NA: 0.5; Cat. A4a.2
(z.B. Mitsubishi Optohome RHEE 4002, GHV 4002)



homefibre digital network gmbh

Fratresstrasse 20
9800 Spittal /Drau
Austria

Contact us:

E-Mail: welcome@homefibre.at

Phone: +43 4762 35391

Fax: +43 4762 42780

More Information:

Web: www.homefibre.at

Webshop: www.homefibre24.at

Your local partner: